

TLSS Spiral Conveyor



It is mainly used to convey particle or powder materials such as grain, oil producer and feed.

The machine has special specifications according to the users' requirements.

- Well-knit structure
- Cover little space
- Wide application

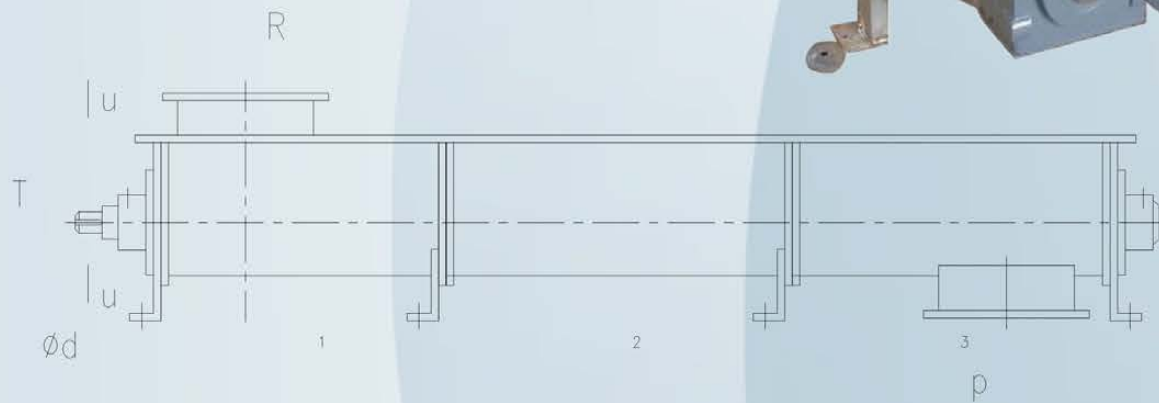

Model	Items	Diameter of Screw (mm)	Pitch (mm)	Rotating Speed (rpm)	Transport Volume (T/h)		Power of Shaft per Meter (kW/t.m)	
					Wheat	Flour	Wheat	Flour
TLSS16		160	130	90	3.5	1.24	0.02	0.007
TLSS20		200	160	90	6.7	2.33	0.042	0.014
TLSS25		250	200	90	13	4.55	0.08	0.028
TLSS32		320	260	90	27.9	9.69	0.17	0.06
TLSS40		400	320	90	53.6	19.63	0.33	0.115

DSG Belt Conveyor



It is used to horizontal conveyance or conveyance of particle materials with small angle in grain store, cereals, milling factories, etc.

- Various specifications
- Customized specifications

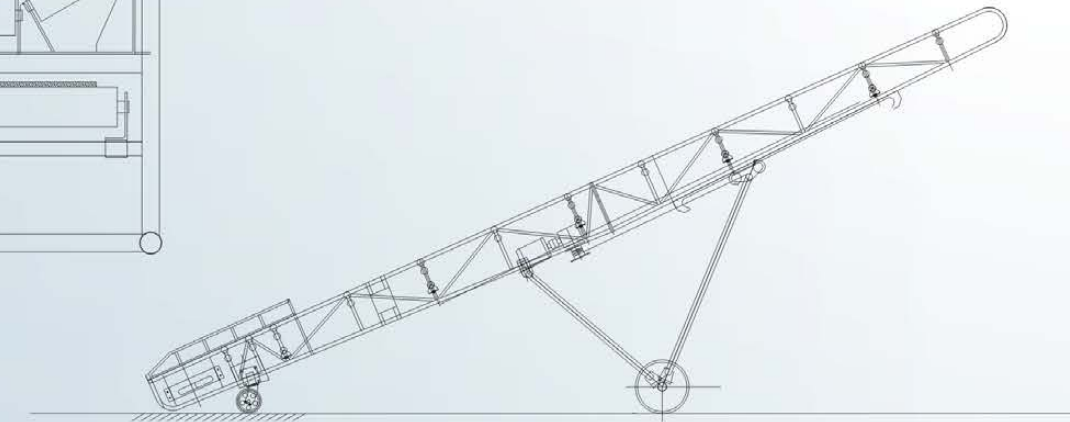
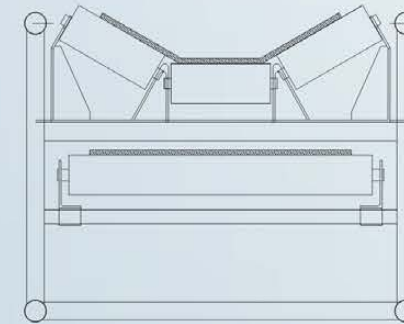

Items	Model	DSG40	DSG50	DSG65	DSG80
Belt width(mm)		400	500	650	800
Capacity(t/h)		50	100	200	300
Speed(m/s)		2.5	3.15	3.15	3.15
Head shaft diameter(mm)		240	240	320	400
Tailwheel diameter(mm)		200	200	240	320
Distance of conveying(m)		L ≤ 100	L ≤ 100	L ≤ 100	L ≤ 100
Stretch distance (m/m)	S ≤ 50m	500	500	500	500
	S ≤ 100m	800	800	800	800
Angle of support roller(m°)		35	35	35	35
Dia of support wheel(mm)		60	60	76	76
Distance between roller (mm)	Upper roller	1250	1250	1250	1250
	Return roller	2500	2500	2500	2500
Height(mm)		600	600	600	700

Closed Three Roller Air Cushion Conveyor



The machine is mainly used to transport bulk material.

- Special enclosed three roller structure
- Save power
- Start flexibly
- Long service life
- Easy to replace and maintain
- Special movable roof structure

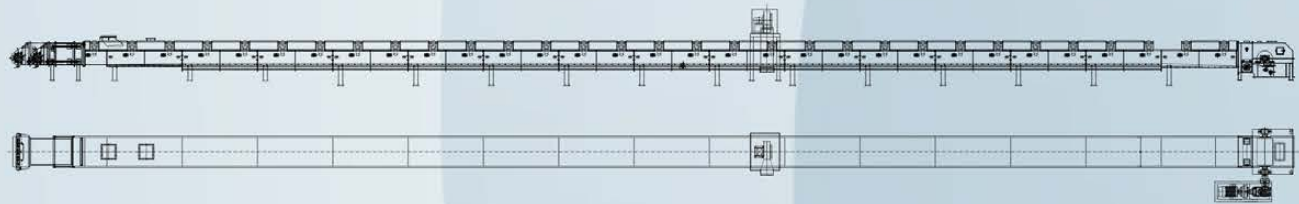

Multiple Discharge Belt Conveyor

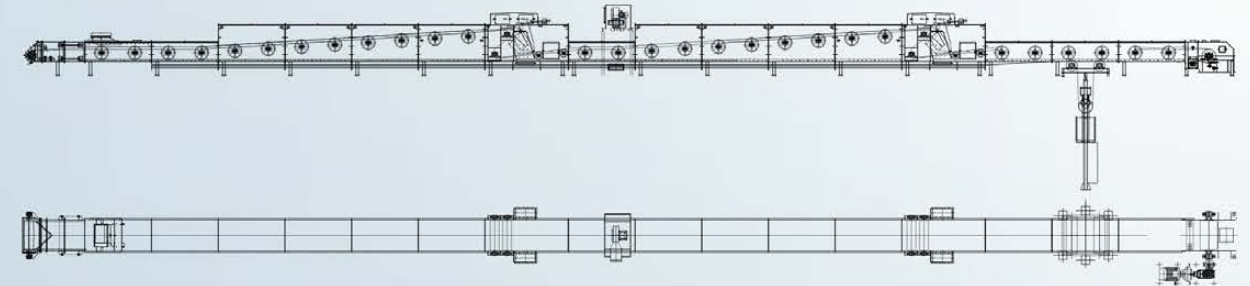

It is used for multipoint discharge of belt conveyor.

- Domestic initiative
- Special distributor
- Simple structure
- Reliable use
- Online conversion
- Remote control
- Little material leakage
- Low height
- Space saving
- Convenient layout